



Corr-Vac® Mark III Bulk Bin - Roll Around

**FLEXIBLE MODIFIED
ATMOSPHERE
PACKAGING SYSTEM**

*Clean, simple design, for
maximum reliability and
ease of maintenance.*

Features and Options

- 100% stainless steel and FSMA, FDA, & USDA compliant. Optional 3A dairy-grade
- Always ready for wash-down as we build-to IP69 specifications assuring IP67 compliance
- Seal bars available include either 30, 54, and 62-inch lengths
- Vacuum pump or optional liquid-ring and venturi
- Hot-bar or impulse sealing
- Bag-stretcher option to insure wrinkle free bags
- One or optional two hand controls
- Flexible probes reduces damage and extends life
- A variety of language options on our simple to understand controller
- Floor mount or optional suspend over conveyor

Applications

- Vacuum and gas flush cases, gaylords, barrels, super-sacks - extends shelf life of proteins
- Vacuum followed by dual gas flush mix extends shelf life and product color of red meats
- Gas flush any product that degrades in atmosphere
- Multi-gas flush totes or super-sacks of organic products assuring inserts and larvae are asphyxiated
- Poultry, beef & pork, prepared meat, cheese, fish, nuts, powders, organic, industrial

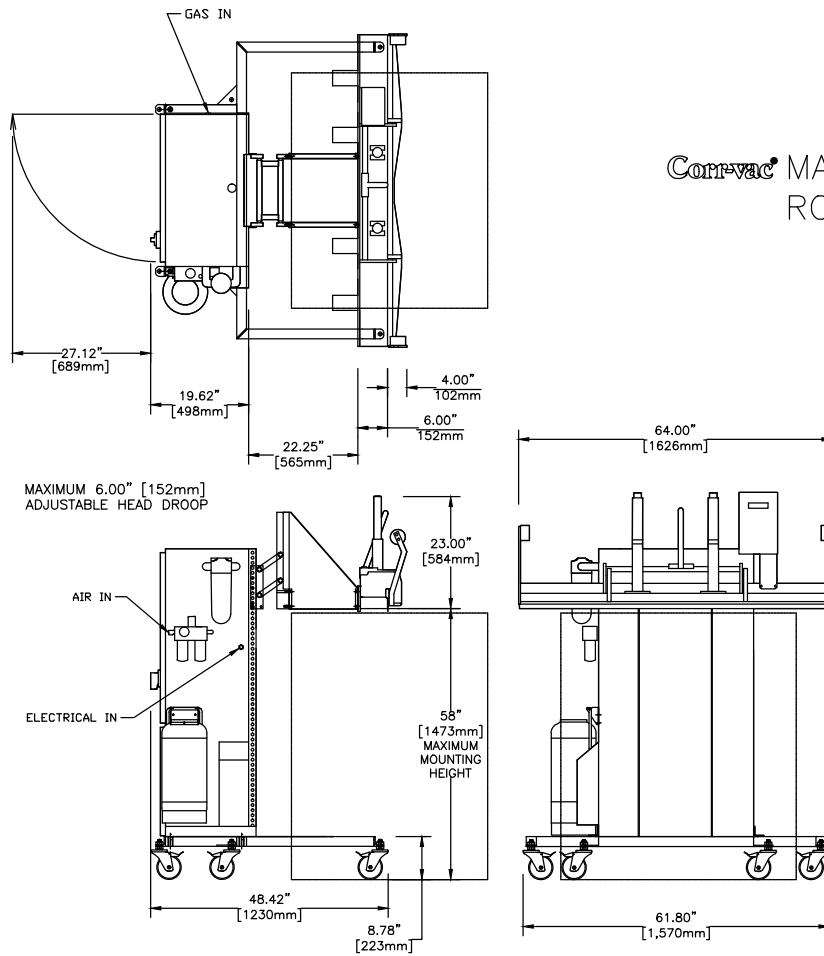

Corvac MARK III BULK BIN
ROLL-AROUND



VFFS



Individual Bags



Case Ready



Top Load



Bulk Bin Rollaround



Bulk Bin Suspended



HSP

